

ACCESSORIES

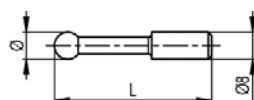

		TVM	V/V Plus	VT	M/MT
TV2S2 279 901007 010	Cone Ø 0-15 mm	•			
TV2S3 279 901007 003	Cone Ø 13-20.5 mm	•			
TV2S4 509 05 20 0001	Cone Ø 17-24.5 mm	•			
TV2S5 279 901007 005	Cone Ø 23-30.5 mm	•			
TV2S6 279 901007 006	Cone Ø 26-35.5 mm	•			
TV2S7 279 901007 007	Cone Ø 32-39 mm	•			
TV2S8 279 901007 008	Cone Ø 36-45 mm	•			
TV2S9 279 901007 009	Cone Ø 41-50 mm	•			
TV2S10 279 901007 010	Cone Ø 46-55 mm	•			
TV2S11 279 901007 011	Cone Ø 51-60 mm	•			
TVM2.9 509 05 20 0001	Ball insert Ø 0.5 mm	•			
TVM2.8 509 05 20 0003	Ball insert Ø 1 mm	•			
TVM2.4 509 05 20 0009	Ball insert Ø 2 mm	•			
TVM2.3 509 05 20 0014	Ball insert Ø 3 mm	•			
TVM2.2 509 05 20 0025	Ball insert Ø 4 mm	•			
TVM2.6 509 05 20 0031	Ball insert Ø 5 mm	•			
TVM2.1 509 05 20 0037	Ball insert Ø 6 mm	•			
TVM2.7 509 05 20 0045	Ball insert Ø 7 mm	•			
TVM2 509 05 20 0051	Ball insert Ø 8 mm	•			

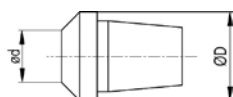

TVM



V/V Plus



VT



M/MT

ACCESSORIES

			TVM	V/V Plus	VT	M/MT
	TVM2.5 509 05 20 0059	Disc shaped insert \varnothing 8 mm	●			
	TVM3 609 12 003	Scriber	●			
	TVM1003 609 12 002	Scriber for TVM1000	●			
	TV7.1 609 05 023	Knife-edge insert		●		
	TV7.2 609 05 022	Ball insert \varnothing 3 mm		●		
	TV7.3 609 05 020	Pin chaped insert \varnothing 2 mm		●		
	TV7.4 609 05 019	Disc shaped insert \varnothing 5 mm		●		
	TVA9.1 509 05 20 0011	barrel-shaped insert M3-M16		●	●	●
	TVA9.2 509 05 20 0029	barrel-shaped insert M6-M48		●	●	●
	TVA9.3 509 05 20 0062	barrel-shaped insert M12-M150		●	●	●
	TA-MI-111 509 05 20 0078	Measuring insert with tungst. carb. ball, \varnothing 1 mm		●	●	●
	TA-MI-110 509 05 20 0077	Measuring insert with tungst. carb. ball \varnothing 2 mm		●	●	●
	TA-MI-104 509 05 20 0080	Measuring insert with tungst. carb. ball \varnothing 2mm		●	●	●
	TA-MI-103 509 05 20 0076	Measuring insert with ruby ball \varnothing 2 mm		●	●	●

ACCESSORIES

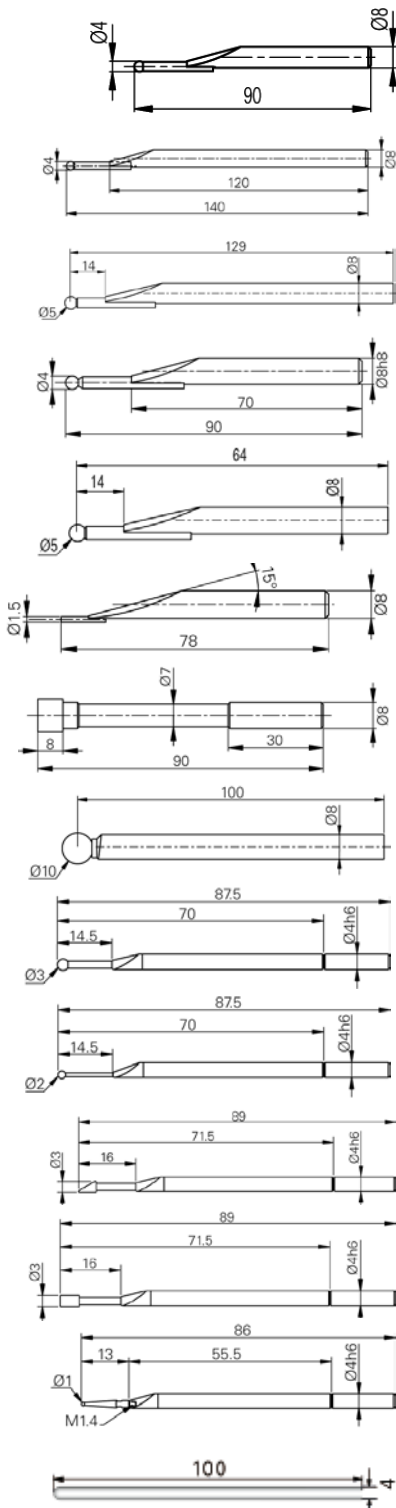

		TVM	V/V Plus	VT	M/MT
TA-MI-102 509 05 20 0075	Measuring insert with tungst. carb. ball Ø 4 mm		•	•	•
TA-MI-105 509 05 20 0079	Measuring insert with tungst. carb. ball Ø 4 mm		•	•	•
TA-MI-106 279 918011 004	Measuring insert with ruby ball Ø 5 mm		•	•	•
TA-MI-101 509 05 20 0074	Measuring insert with ruby ball Ø 4 mm		•	•	
TA-MI-119 SP279 918011 005	Measuring insert with ruby ball Ø 5 mm				•
TA-MI-107 509 05 20 0081	Measuring insert with pin Ø 1.5 mm		•	•	•
TA-MI-112 509 05 20 0082	Measuring insert with parallel faces		•	•	•
TA-MI-108 279 918011 002	Measuring insert with ruby ball Ø 10 mm		•	•	•
TA-MI-109 279 918011 003	Measuring insert with ruby ball Ø 3 mm		•	•	•
V-50.9 279 918011 001	Measuring insert with ruby ball Ø 2 mm		•	•	•
V-50.10 279 918007 001	Knife-edge insert		•	•	•
V-50.11 279 918013 001	barrel-shaped insert Ø 3 x 5 mm		•	•	•
V-50.12 279 918012 001	Measuring insert Ø 1 mm with holder		•	•	•
TA-MI-114 506 22 20 0063	Pin, 1 hemispheric and 1 plane face		•	•	•



TVM



V/V Plus





VT





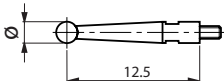
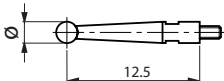
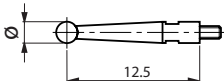
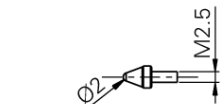
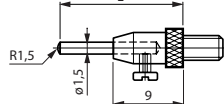
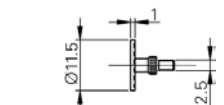
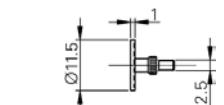
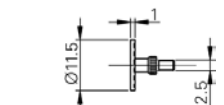
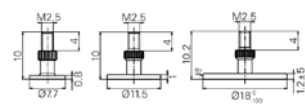
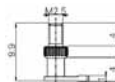
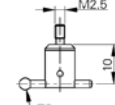

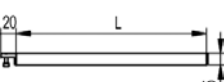
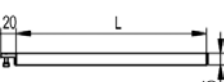
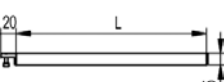
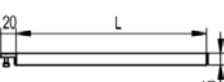

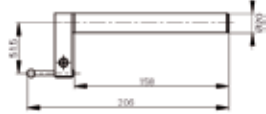
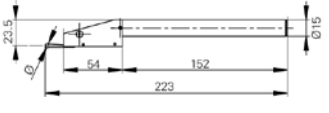

M/MT

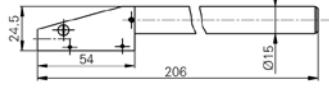
ACCESSORIES

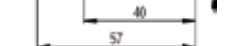
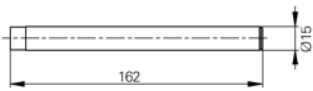
		TVM	V/V Plus	VT	M/MT
	TA-MI-115 279 901001 001 		●	●	●
	TA-MI-116 279 901001 002 		●	●	●
	TA-MI-117 279 901001 003 		●	●	●
	V-50.4 279 918010 001 		●	●	●
	TA-MI-118 279 901003 001 		●	●	●
	V-50.2.1 279 918005 002 		●	●	●
	V-50.2.2 279 918005 003 		●	●	●
	V-50.2.3 279 918005 004 		●	●	●
	V-50.2 279 918005 001 		●	●	●
	V-50.3 279 918008 001 		●	●	●
	V-50.1 279 918009 001 		●	●	●
	TVM1.1 502 02 10 0015 	●			
	TVM1 612 11 007 	●			
	TVM1/L250 612 11 061 	●			
	TVM1/L300 612 11 062 	●			
	TVM1/L350 612 11 063 	●			

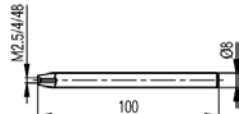
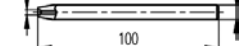
ACCESSORIES

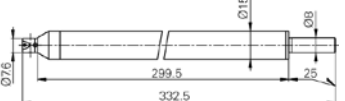
			TVM	V/V Plus	VT	M/MT
	TVM1/1.1/2 609 05 061	Measuring insert + holder (TVM1 + 1.1 + 2)	•			
	TVA1 612 11 028	Measuring insert + holder for TVM1000	•			
	TVM4 609 05 074	Bi-directional probe Ø4 mm	•			
	TVM4.1/4.2 609 05 075	Bi-directional probe Ø2 mm	•			
	TVM4.1 612 11 030	Support pour touche bidirectionnelle	•			
	TVM4.2 609 05 021	Measuring insert Ø2 mm for bi-directional probe	•			
	TVM4.3 609 05 024	Measuring insert Ø4 mm for bi-directional probe	•			
	TVM5.1 609 05 054	Cone holder	•			
	TVM5 709 05 054	Set of cones with holder (TV2S2/3/4/5 + TVMS2)	•			
	TVM6 512 11 20 0018	Holder Ø8 mm for measuring inserts M2.5	•			
	TVM6E 512 11 20 0019	Holder Ø8 mm for measuring inserts 4-48	•			
	TA-IH-101 612 11 045	Measuring insert holder M2.5		•	•	•
	TA-IH-103 612 11 047	Measuring insert holder 4-48		•	•	•
	TA-IH-102 612 11 046	Measuring insert holder M2.5		•	•	•



TVM



V/V Plus









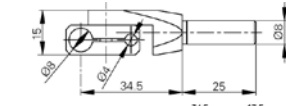
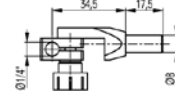

VT

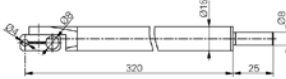



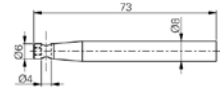
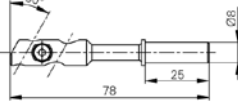
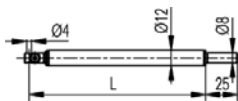
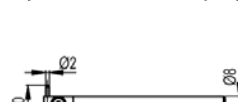
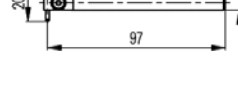
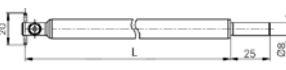





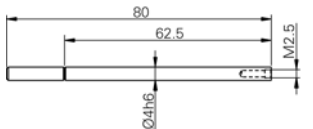
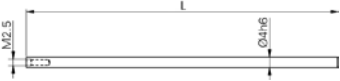

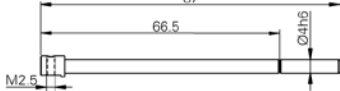
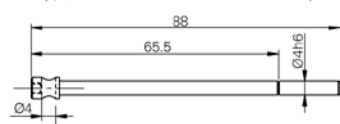
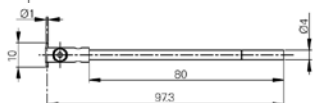
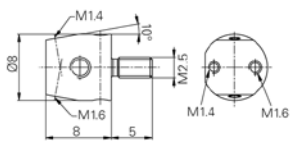
M/MT

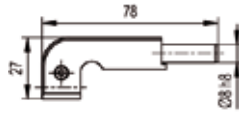
ACCESSORIES

		TVM	V/V Plus	VT	M/MT
 <p>TA-IH-104 612 11 053</p>	Swivel holder \varnothing 4 and 8 mm		•	•	•
 <p>V-2E 612 11 023</p>	Swivel holder \varnothing 1/4 "		•		
 <p>TA-IH-105 612 11 051</p>	Swivel holder \varnothing 4 and 8 mm		•	•	•
 <p>V-2E/D1/4/L150 612 11 013</p>	Swivel holder \varnothing 1/4"		•	•	•
 <p>TA-IH-106 612 11 039</p>	Swivel holder \varnothing 4 and 8 mm		•	•	•
 <p>TA-IH-107 612 11 055</p>	Insert holder 90°, \varnothing 8 mm		•	•	•
 <p>TA-IH-108 612 11 052</p>	Insert holder 90°, \varnothing 8 mm		•	•	•
 <p>TA-IH-109 612 11 054</p>	Insert holder 90°, \varnothing 4 mm		•	•	•
 <p>TA-IH-110 279 918103 001</p>	Insert holder 90°, \varnothing 4 mm		•	•	•
 <p>V-4 612 11 011</p>	Insert holder 30°, \varnothing 4 mm		•	•	•
 <p>TA-IH-111 612 11 041</p>	Insert holder 90°, \varnothing 4 mm, L=150 mm		•	•	•
 <p>TA-IH-112 612 11 042</p>	Insert holder 90°, \varnothing 4 mm, L=300 mm		•	•	•
 <p>TVA4 609 05 007</p>	Insert holder with pin \varnothing 2 x 20 mm		•	•	•
 <p>TA-IH-113 612 11 043</p>	Insert holder with pin \varnothing 2 x 20 mm, L=200 mm		•	•	•
 <p>TA-IH-114 612 11 044</p>	Insert holder with pin \varnothing 2 x 20 mm, L=300 mm		•	•	•

ACCESSORIES

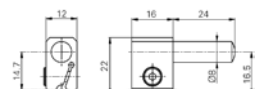
		TVM	V/V Plus	VT	M/MT
	V-50.6 279 918002 002		•	•	•
	V-50.5 279 918002 001		•	•	•
	TA-IH-115 279 918002 003		•	•	•
	V-50.7 279 918001 002		•	•	•
	V-50.8 279 918001 001		•	•	•
	TA-IH-116 279 918001 003		•	•	•
	TA-IH-117 512 11 20 0012		•	•	•
	TA-IH-118 512 11 20 0013		•	•	•
	TA-IH-126 612 07 006			•	•
	TA-MS-101 276 940001 001			•	•
	TA-MS-102 276 940001 002			•	•
	TA-MS-103 609 02 020			•	
	TA-MS-104 609 02 021			•	
	TVM1010 603 12 005	•			
	V-5 612 11 012		•	•	•



TVM



V/V Plus



VT





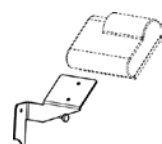
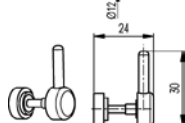
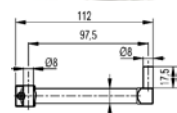
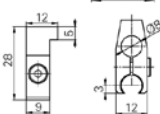
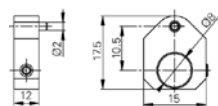

M/MT

ACCESSORIES



		TVM	V/V Plus	VT	M/MT
TA-AD-101 603 11 001	Positioning holder for measuring insert VT/MT			●	●
TA-AD-102 603 11 002	Positioning holder for measuring insert V+		●		
TA-AD-104 SP612 05 014 01	Mobile support for display VT/MT			●	●
V-7/H100 612 11 025	Extension for probe holder 100 mm		●		
V-20 606 00 029	Quick clamp for insert holder		●		
V-32 612 06 001	Printer holder for V+		●		
V-32/SP SP612 06 001 01	Printer holder for VT/MT (factory mounted only)			●	●
TA-SE-101 605 01 007	Set of accessories "Macro" (16 pcs)		●	●	●
TA-SE-102 605 01 008	Set of accessories "Micro" (20 pcs)		●	●	●
TA-MG-103 609 01 026	Setting gauge		●		
TA-MG-101 609 01 024	Setting gauge 25 mm			●	●
TA-MG-102 609 01 025	Setting gauge 1"			●	●
V-60 612 12 045	Wooden accessories support		●	●	●
V-50.13 290 918001 001	Wrench for measuring inserts		●	●	●

ACCESSORIES

			TVM	V/V Plus	VT	M/MT
	V-50.15 290 000911 005	Allen key 2.5 mm		•		
	TA-TO-001 290 000911 009	Allen key 5 mm			•	•
	TA-TO-002 290 920001 001	Hex Screwdriver 2 mm		•	•	•
	LABC-30.3 3708 0002	Touch screen pen			•	•
	TVM.HO300 505 05 10 0009	Protection cover for TVM301, TC401	•			
	TVM.HO600 505 05 10 0011	Protection cover for TVM601, TC601	•			
	TVM.HO1000 505 05 10 0013	Protection cover for TVM1000	•			
	V.HO300 505 05 10 0020	Protection cover for V300		•		
	V.HO600 505 05 10 0021	Protection cover for V600		•		
	V.HO1000 505 05 10 0022	Protection cover for V1000		•		
	TA-TO-109 505 05 10 0005	Protection cover for VT/M/MT 300			•	•
	TA-TO-110 505 05 10 0006	Protection cover for VT/M/MT 600			•	•
	TA-TO-111 505 05 10 0007	Protection cover for VT/M/MT 1000			•	•
	TA-TO-112 505 05 10 0008	Protection cover for VT 1500			•	
TA-TO-113 505 05 10 0037	Protection cover for VT 2000			•		



TVM



V/V Plus















VT



M/MT

ACCESSORIES



			TVM	V/V Plus	VT	M/MT
	BAT-TVM.OPTO 3705 0002	Battery	●			
	TELMA31 3706 0002	Foot pedal		●		
	TA-EL-101 3706 0006	Foot pedal (VT/MT)			●	●
	LABC-40 356 0010	Laser printer (USB)			●	●
	TA-EL-030 356 0016	Inkjet printer (USB)			●	●
	V-30 356 0007	Printer (RS232)		●	●	●
	TVM.O-PC/AT.9P 333 9 0003	Cable Opto-PC / AT 9 P/F 2 m	●			
	V-31 333 0 0003	Cable for RS232 printer		●		
	CABL.RS.1/1-9P 332 01 0001	Cable RS232 m/f, 1.8 m (VT/M/MT: Printer & V / V Plus / H: PC)		●	●	●
	TA-EL-110 332 01 0012	Cable RS232 f/f, 1.8 m (PC)			●	●
	TA-EL-013 332 02 0001	USB A-B connection cable, L=1.8 m			●	●
	TA-EL-011 358 0006	USB-RS232 Converter	●	●	●	●
	TA-EL-131 334 0020	Universal AC adapter, 9 V (without cable)		●		

ACCESSORIES

			TVM	V/V Plus	VT	M/MT
	TA-EL-130 357 0100	Universal AC adapter, 28 V (without cable)			•	•
	TA-EL-001 332 10 0011	Power cable, 2 poles, Europe		•	•	•
	TA-EL-002 332 10 0013	Power cable, 2 poles, USA/Japan		•	•	•
	TA-EL-003 332 10 0016	Power cable, 2 poles, Australia		•	•	•
	TA-EL-004 332 10 0014	Power cable, 2 poles, UK		•	•	•
	TA-EL-005 616 20 003	Power cable, 2 poles, Korea		•	•	•
	V-30.7 788 000001 001	Paper rolls (5 pcs)		•		
	TA-EL-120 609 50 005	Temperature compensation system			•	
	TA-EL-121 616 70 001	Wireless communication system "Wi-Fi"			•	•
	TA-EL-122 616 70 002	Wireless communication system "Bluetooth"			•	•
	TA-EL-123 609 50 006	Temperature compensation system "Wi-Fi"			•	
	TA-EL-124 609 50 007	Temperature compensation system "Bluetooth"			•	
	TA-EL-140 358 0008	USB memory stick			•	•
	TA-SW-001 394 1 0050	Software for data transfer WinDDE	•	•	•	•



TVM



V/V Plus



VT



M/MT

ACCESSORIES



TA-SE-101
605 01 007

Set of accessories Macro (16 pieces):

- TA-MI-105** Measuring insert with tungst. carb. ball Ø4 mm, L=140 mm
- TA-MI-110** Measuring insert with tungst. carb. ball Ø2 mm, L=80 mm
- TA-MI-107** Measuring insert with pin Ø1.5 mm, L=78 mm
- TA-IH-105** Swivel holder Ø4 and Ø8 mm, L=150 mm
- TA-IH-109** Insert holder 90°, Ø4 mm
- TVA4** Insert holder with pin Ø2 x 20 mm
- TA-IH-101** Measuring insert holder M2.5, L=103 mm
- V-50.5** Measuring insert holder M2.5, L=124 mm
- TA-IH-115** Measuring insert holder M2.5, L=200 mm
- V-50.4** Measuring insert M2,5 with ball contact
- V-50.2.3** Disc-shaped inserts M2.5, Ø18 mm
- TA-MI-115** Measuring insert M1.4 with ball Ø1 mm, L=12.5 mm
- TA-MI-116** Measuring insert M1.4 with ball Ø2 mm, L=12.5 mm
- TA-MI-117** Measuring insert M1.4 with ball Ø3 mm, L=12.5 mm
- V-50.13** Wrench for measuring inserts
- V-50.15** Allen key 2.5 mm

TVM
V/V Plus
VT
M/MT

• • •



TA-SE-102
605 01 008

Set of accessories Micro (20 pieces):

- V-50.4** Measuring insert M2,5 with ball contact
- TA-MI-118** Measuring insert M2.5 with 4 interchangeable pins
- V-50.2.1** Disc-shaped inserts M2.5, Ø7.7 mm
- V-50.2.2** Disc-shaped insert M2.5, Ø11.5 mm
- V-50.3** Corner insert M2.5
- TA-MI-115** Measuring insert M1.4 with ball Ø1 mm, L=12.5 mm
- TA-MI-116** Measuring insert M1.4 with ball Ø2 mm, L=12.5 mm
- TA-MI-117** Measuring insert M1.4 with ball Ø3 mm, L=12.5 mm
- TA-IH-117** Holder for measuring inserts M2.5, M1.6, M1.4
- V-50.6** Measuring insert holder M2.5
- V-50.8** Insert holder 90°, Ø4 mm
- TA-IH-116** Measuring insert holder, Ø1 x 10 mm, L=80 mm
- V-50.9** Measuring insert with ruby ball Ø2 mm, L=88 mm
- V-50.12** Measuring insert Ø1 mm with holder, L=86 mm
- V-50.10** Knife-edge insert
- V-5** Reduction Ø 8 / 4 mm
- TA-IH-104** Swivel holder Ø4 and Ø8 mm
- V-50.13** Wrench for measuring inserts
- TA-TO-003** Allen key 1.5 mm
- V-50.15** Allen key 2.5 mm

• • •