

TR SCAN PREMIUM



TR SCAN PREMIUM

INTRODUCTION

TR Scan Premium allows the measuring of the most sensitive surfaces with astounding speed and precision. It has become unavoidable in many cases for hi-tech applications, when the traditional measuring by contact has reached its limits. Medical appliances, prosthesis, wafers, MEMS, semi-conductors, metallic layers deposits, polymer films, optical components, research and development, quality control, are the areas of expertise of TR Scan Premium.

The heart of the system, Trimos DHM® (Digital Holographic Microscopy), constitutes a derivation of a technology used in the biomedical engineering field. The system itself is based on the physical characteristics of the hologram for the topography generation of the analysed surface. This technology for checking industrial surfaces is exclusively used by Trimos. Its most distinctive feature to competitive products is the possibility of measuring extreme reflecting, mirror-polished or very small surfaces.

The exceptional high measuring speed coupled with an accuracy range of a nanometre form the main advantages of the TR Scan. Only some microseconds are needed for the acquisition of a three dimensional image (x, y, z) with a million points. This exceptional acquisition speed allows ignoring all problems traceable to vibrations, the traditional enemy of the majority of optical measuring systems. The mentioned advantages prove an enhanced productivity and a limited investment.

EXCEPTIONAL FAST MEASURING SPEED

INSENSITIVE TO VIBRATION

VERTICAL RESOLUTION IN NANOMETER RANGE

EXTREME SIMPLE POSITIONING OF THE PART THANKS TO LASER ALIGNMENT (DHM)

NON-CONTACT MEASURING, NON DESTRUCTIVE

SOFTWARE AT THE TOP OF THE TECHNOLOGY

PRE-PROGRAMMED MEASURING PROCESSES

COMPATIBLE WITH 2D AND 3D STANDARDS

DESCRIPTION

AUTOMATED Z-AXIS

The motorization of the axes allows entirely automatic measurements. The working distance is automatically given by the system. The measurement of surfaces wider than the field of vision of the lens is made possible thanks to a particularly efficient "stitching" function.



INTERCHANGEABLE MEASURING HEADS

The unique system of interchangeable measuring heads confers a high degree of adaptability to every application. Changing a head is quickly done and automatically recognized by the system. Several technologies are available for complete application coverage.

TRIMOS NANOWARE MEASURE

Software for the management of all measurement parameters

TRIMOS NANOWARE ANALYSIS

Software for the analysis of measured surfaces



Motorized table (XY)

TR SCAN PREMIUM

DISPLAY / SOFTWARE

TRIMOS NANOWARE MEASURE

This exclusive software allows the handling of the instrument (positioning and configuration of all measurements).

Positioning in X,Y,Z is performed either automatically by pre-defined parameters or via the use of an intuitive joystick aided by a integrated positioning laser and a camera (optional).

Once positioned, measurements are taken automatically with one click or via the use of a manual size parameter in a few seconds.

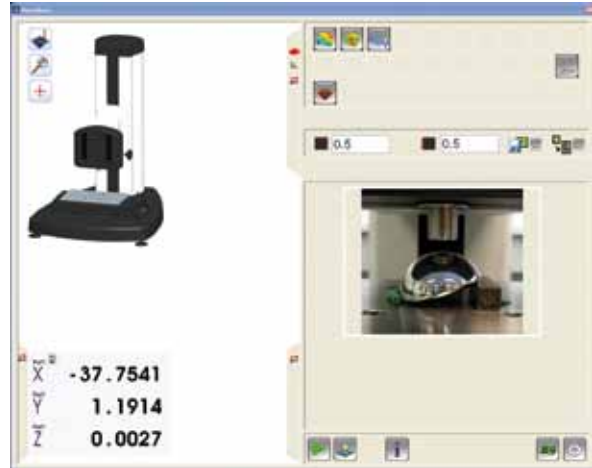

INTUITIVE POSITIONING

INSTANT MEASUREMENT

PROGRAMMABLE MEASUREMENTS WITH PICTURE

TRIMOS NANOWARE ANALYSIS

This software allows the analysis of all measured surfaces according to current international standards such as ISO, DIN, JIS, ASME, CNOMO etc., as well as the 3D standard ISO 25178.

Analysis can be performed automatically by the use of a template or the user can have direct access to the raw data. The incorporated analysis software is powered by Mountains®, the most powerful and recognized 2D/3D surface analysis software available.

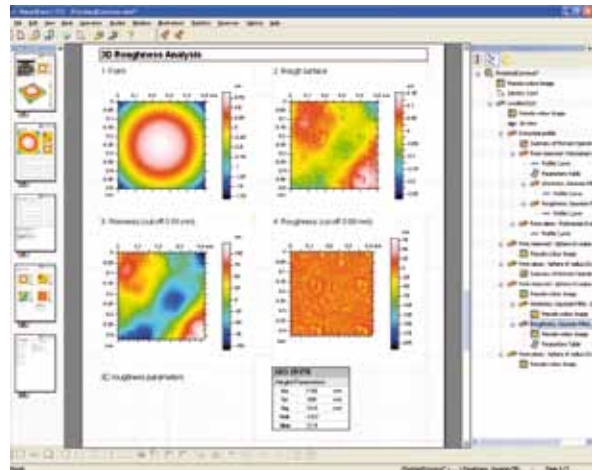

Reports are automatically generated during analysis. Any report can be used as a template later.

POWERFUL ANALYSIS

PROFESSIONAL REPORTING

SUITABLE MODULE FOR EACH APPLICATION NEED

COMPLIES TO ALL INTERNATIONAL STANDARDS

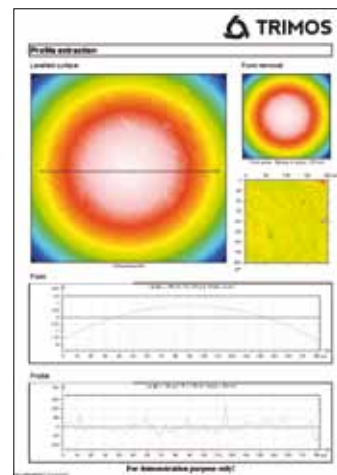

THE DHM TECHNOLOGY

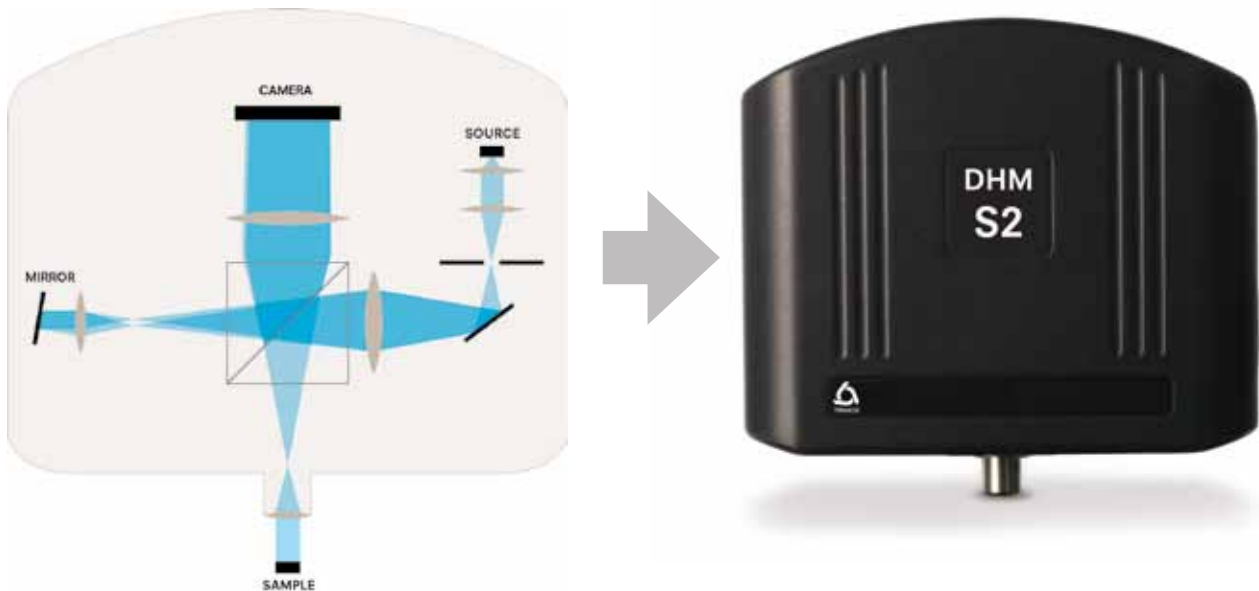

DHM® (Digital Holographic Microscopy) is a non-contact surface measurement technology originally developed for the biotech and medical industry. DHM generates a high-resolution 3D digital image of a sample using the principle of holography. A hologram generated by combining a coherent reference wave with the wave received from a sample is recorded by a CCD camera and transmitted to a computer for numerical reconstruction.

A single hologram is acquired in a few microseconds, making the whole system insensitive to vibrations. Software procedures allow computation of the complete wavefront emanating from an object and provides:

- Intensity images providing the same contrast as with classical optical microscopy

- Phase images providing quantitative data, defined at a sub-wavelength scale, used for accurate and stable 3D measurements.

The phase image reveals the surface topography with a sub-nanometric vertical resolution. This digital approach to holography allows the application of computer-based procedures at a level never reached in optical microscopy so far. In particular the DHM principle features software compensation of optical aberrations, digital image focusing and numerical compensation for sample tilt and environmental disturbances, making DHM instruments robust and easy to use for routine inspections at the nanometer and micrometer scale. DHM is used exclusively by Trimos for surface texture measurement. This technology has numerous advantages compared to other contact and non-contact measurement technologies: in particular extremely fast measurements, high resolution, simple working process no moving parts and no requirement for special environmental conditions.

- Acquisition in a few microseconds
- Vibration insensitive
- High image quality
- Subnanometric resolution
- No moving parts
- No requirement for special environmental conditions

DHM is a recognized surface texture measurement method according to the standard ISO 25178-6

TR SCAN PREMIUM

MEASURING HEADS

DHM S1 & S2

DHM Technology:

- Smooth, grinded and polished surfaces
- Steel, aluminum, titanium, silicon, gold, ceramics, glass
- High precision and speed, 2D/3D

CCM P1

Chromatic Confocal Technology:

- Machined and rough surfaces, micro-structures
- Metals, plastics, abrasives, papers, textiles, cosmetics
- Large vertical range, all materials, 2D/3D

DIA P1

Diamond Stylus Tip Technology:

- Roughness measurement with contact
- Classical roughness measurements (2D)
- Internal measurements

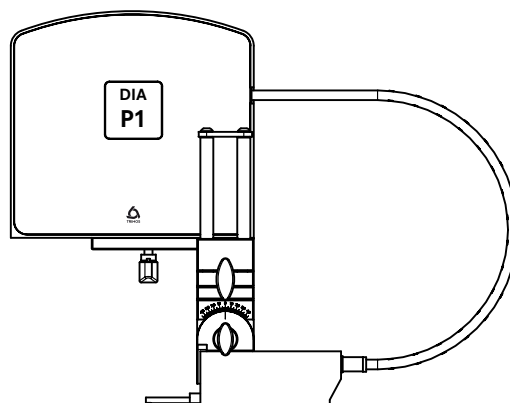
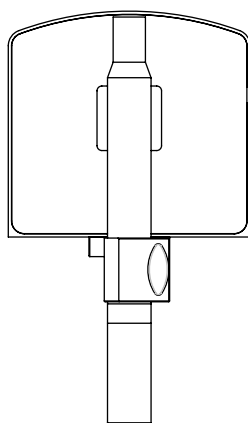
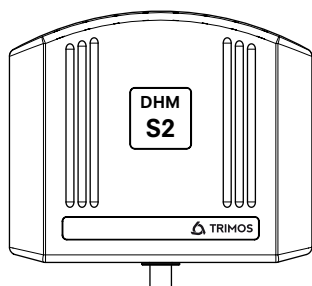

TECHNICAL SPECIFICATIONS

TR Scan Premium		101	301
Horizontal measuring range X	mm	-	100
Horizontal measuring range Y	mm	-	100
Vertical measuring range Z	mm	240	
Measuring system resolution XYZ	µm	0.1	
Positioning accuracy XYZ	µm	1	
Rectitude of the guideways XY	µm	0.3	
Max weight of the part	kg	20	

Measuring Heads		DHM S1	DHM S2	CCM P1	DIA P1
Vertical resolution (Z)	nm	0.1	0.1	8 ÷ 780 ²⁾	10
Lateral resolution (XY)	µm	0.6	0.6	0.9 ÷ 14 ²⁾	1
Typical measuring range Ra ¹⁾	µm	0.4	1.6	0.012 ÷ >200 ²⁾	20
Vertical measuring range ¹⁾	µm	3	7	130 ÷ 24000 ²⁾	350
Max. permissible errors Ra	%	1%	1%	1% ÷ 5% ²⁾	5%
Repeatability (Ra, 1σ)	nm	< 0.1	< 0.1	<5 ÷ 25 ²⁾	9
Sample reflectivity	%	< 1% ÷ 100%	< 1% ÷ 100%	1% ÷ 100%	-
Field of view	mm	0.25 x 0.25	0.25 X 0.25	-	-

¹⁾ Values may differ depending on the surface texture

²⁾ Objective dependent

DIAGRAM

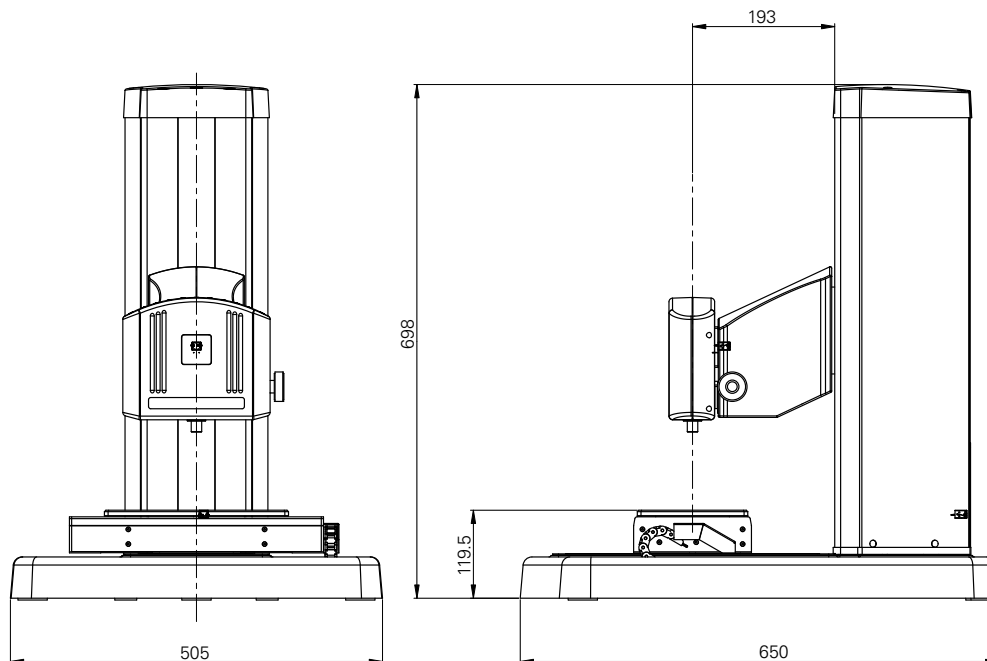

STANDARD INSTRUMENT

The TR Scan Premium instruments are supplied as follows:

Instrument according to specification (without measuring head)

1 measuring head (DHM S1, DHM S2, CCM P1+TA-MI-701 ÷ 713)

PC with 1 TFT screen

Nanaware Measure and Nanaware Analysis softwares (according to selected model)

User's manual (750 50 0028 03)

CODE NUMBER

TR Scan Premium	Purpose	Meas. head	Axes	Software
TRSP101DHM 700 405 10 11	3D Measurement of tiny parts	DHM S2	- 1 vertical axis Z	Nanaware STT (2D/3D analysis)
TRSP301DHM 700 405 30 21	3D measurement of metallic parts	DHM S2	- 1 vertical axis Z - 2 horizontal axes XY	Nanaware STT (2D/3D analysis)
TRSP301CCM 700 405 30 31	Universal 3D measurements	CCM P1	- 1 vertical axis Z 2 horizontal axes XY	Nanaware STT (2D/3D analysis)

TR Scan Premium can also be specifically equipped according to each application need (head(s) and measuring table, software). An exhaustive list of equipments can be found in the accessories section.

TR SCAN PREMIUM

APPLICATIONS

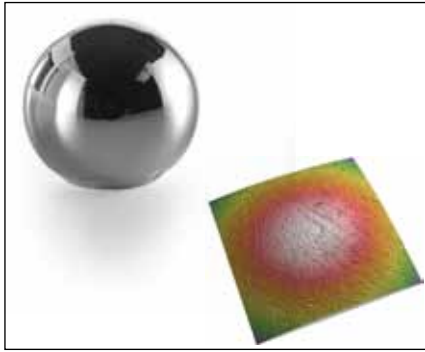

Quality control of a cobalt-chromium polished prosthesis surface (DHM-S2)

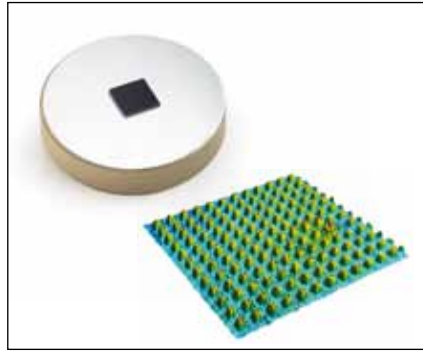

Analysis of a silicon microstructure (DHM S2)

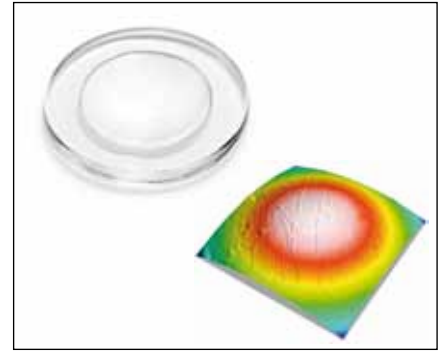

Roughness inspection of micro lenses (DHM S2)

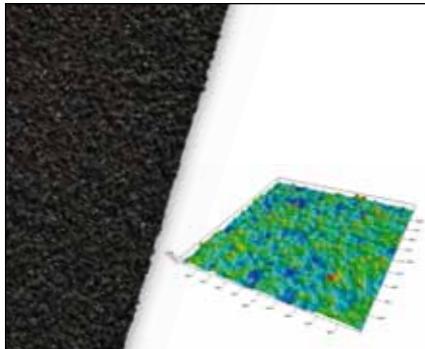

Surface texture analysis of an industrial abrasive material (CCM P1)

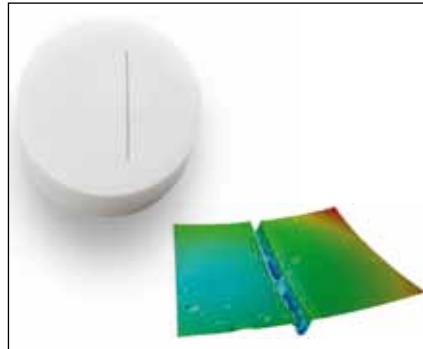

Depth measurement of a laser engraving on ceramics (CCM-P1)

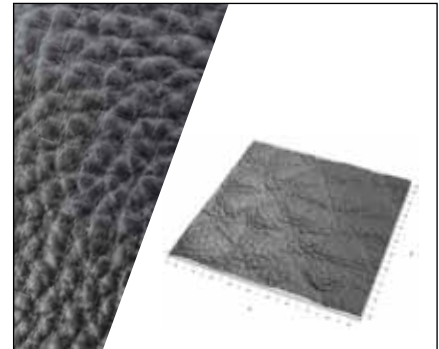

Topographic analysis of a leatherette sample (CCM-P1)



Measurement of macroscopic surface textures (CCM P1)